

### FEATURE OF PRODUCT ( TÍNH NĂNG SẢN PHẨM)

- ✓ Vacuum pads for the electronics and semiconductor industries.
- ✓ Suitable for thick and flat work-piece.
- ✓ Small-size for semiconductor parts.
- ✓ Nắm hút chân không cho công nghiệp điện tử và chất bán dẫn.
- ✓ Phù hợp cho các các vật nâng dày và phẳng.
- ✓ Cỡ nhỏ cho các linh kiện bán dẫn.

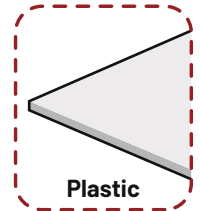

### APPLICATION ( ỨNG DỤNG)

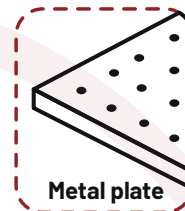
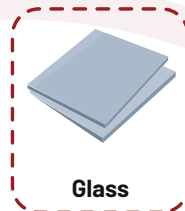
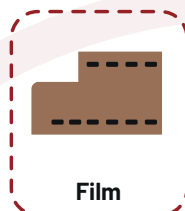
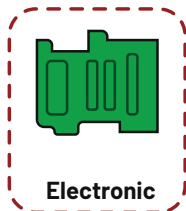

### HOW TO ORDER ( CÁCH ĐẶT MÃ)

Principle :

**SUFFIX - TYPE/SIZE - ADAPTER - MATERIAL/RESISTANCE/MARK-FREE/COLOR - DN**

	(1)	(2)	(3)	(4)	(5)
<b>Example</b>	1	FG15	X6	SE	2

**(1) SUFFIX**

**(2) FG:** Loại cơ bản ( Standard type)

**Size (Cỡ nắm) :** Ø10, Ø15, Ø20, Ø25, Ø30.. (Diameter mm)

**(3) Adaptor:**

X - Cylinder type

XO - Cylinder Oval type

Y - Cone type

Z - Screw type

V - Anchor type

T - Barb-Cylinder type

P - Pillar type

K - Lock ring type

KV - Anchor-Lock ring type

KO - Oval-Lock type

**Adaptor size:** Ø1, Ø2, Ø3, Ø4, Ø5, Ø6, Ø7, Ø8, Ø9, Ø10, Ø11, Ø12, Ø13, Ø14, Ø15, Ø16, Ø17, Ø18, Ø19, Ø20.

**(4) Material (Vật liệu):****N:** NBR**N49/N69:** Conductive NBR**SE:** Conductive silicone**U:** Urethan rubber**F:** FKM Fluoroelastomer**HN:** HNBR

- Special material can be produced by custom specification.
- Vật liệu đặc biệt có thể được sản xuất theo yêu cầu riêng của khách hàng.

**Resistance (Độ tinh điện)****69:**  $10^6$  to  $10^9$  [ $\Omega$ ]**49:**  $10^4$  to  $10^9$  [ $\Omega$ ]**Blank:** none**(5) Design number**

## DIMENSION (KÍCH THƯỚC)

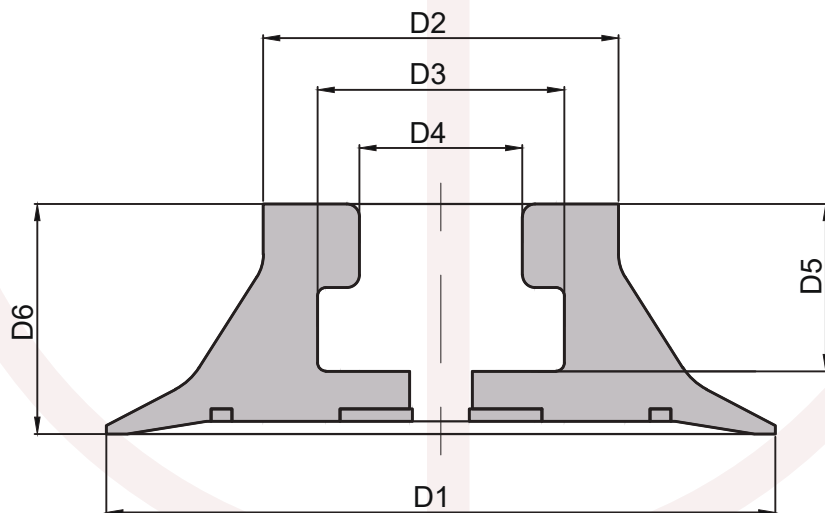

## THANG LONG TECH CO., LTD

Office: 25-26-27 TT3, Kim Quan Thuong Street, Viet Hung ward, Long Bien District, Ha Noi, Viet Nam

Tel: +84-24-3-6230117/0118/0119

Email: [tlt@thanglongtech.com.vn](mailto:tlt@thanglongtech.com.vn)

Website: [www.thanglongtech.com.vn](http://www.thanglongtech.com.vn)